

# REVO VM II PRO series

## Hybrid Energy Storage Inverter

1.5/3/3.5/5.5KW

**SOROTEC**  
Power Solutions Expert



### MPPT

Pure sine wave MPPT solar inverter  
BUILT-IN 80/100A MPPT solar charger



### Battery

Battery equalization function extend lifecycle  
Reserved communication port (RS485, CAN) for BMS



### Off-Grid

REVO VM II Pro series is suitable for off-grid applications.



### Easy access

High PV input voltage range  
With touch buttons



## With battery connected

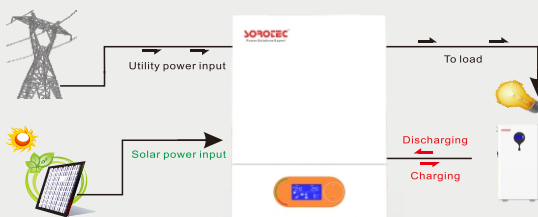

## Without battery connected

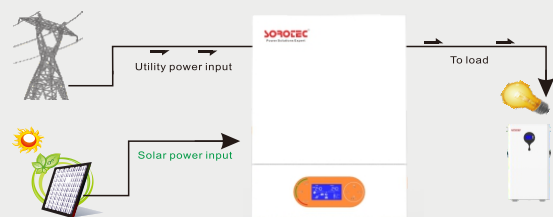

## Schematic diagram

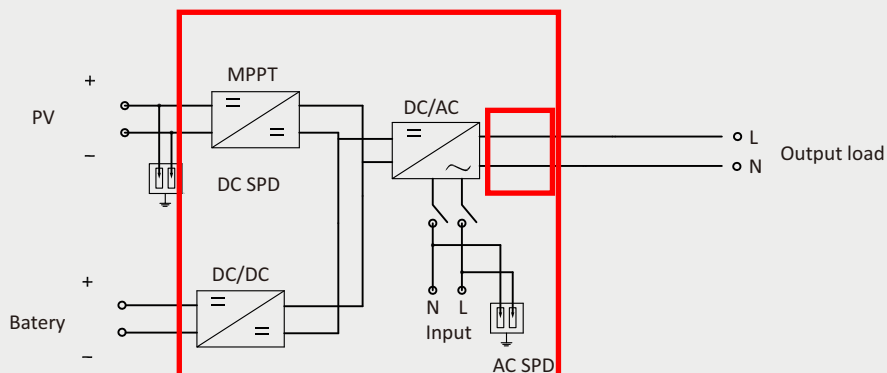

Technical Specification	REVO VM II PRO			
Rated Power	1500VA/1500W	3000VA/3000W	3500VA/3500W	5500VA/5500W
<b>AC INPUT</b>				
Voltage	230VAC			
Selectable Voltage Range	170-280VAC (For Personal Computers) ; 90-280 VAC ( For Home Appliances)			
Frequency Range	50Hz/60 Hz ( Auto sensing)			
<b>AC OUTPUT</b>				
AC Voltage Regulation (Battery Mode)	230VAC $\pm$ 5%			
Surge Power	3000VA	5000VA	7000VA	11000VA
Efficiency (Peak)	up to 93.5%			
Transfer Time	10ms ( For Personal Computers) ; 20ms ( For Home Appliances)			
Waveform	Pure sine wave			
<b>BATTERY</b>				
Battery Voltage	12VDC	24VDC	48VDC	
Floating Charge Voltage	13.5VDC	27VDC	54VDC	
Overcharge Protection	16VDC	33VDC	63VDC	
<b>SOLAR CHARGER &amp; AC CHARGER</b>				
Maximum PV Array Open Circuit Voltage	500VDC			
Maximum PV Array Power	2000W	3000W	4500W	5500W
MPPT Range @ Operating Voltage	90~450VDC		60~450VDC	
Maximum Solar Charge Current	80A		100A	
Maximum AC Charge Current	60A		80A	
Maximum Charge Current	80A		100A	
<b>GENERAL PARAMETER</b>				
Operating Temperature	-10°C to 50°C			
Relative humidity	5% to 95% Relative Humidity ( Non-condensing)			
Dimensions D x W x H (mm)	348*270*95		400*300*115	
Net Weight(KG)	4	5	8.5	9
<b>DISPLAY AND COMMUNICATION</b>				
Communication Interface	Standard: RS232; Optional: CAN&RS485			
Safety standard	EN/IEC 62109-1, EN/IEC 62109-2			